

SPECIFICATIONS	
TORQUE	52,900 lbf.ft [71.7 KN.m]
DRILLING DEPTH	53'ft [16.2 m] / 68' 6" ft [20.8 m] W/EXT
BASE MACHINE	CAT 323
DRILLING SPEED	22 - 36 rpm
SPIN OFF SPEED	95 - 140 rpm
CROWD STROKE	6' 3" [1.92 m]
CROWD FORCE	27,000 lbf [12,300 Kgf]
MAIN WINCH	27,120 lbf [12,330 Kgf] (FIRST LAYER - EFFECTIVE)
SERVICE WINCH	14,300 lbf [6,500 Kgf] (FIRST LAYER - EFFECTIVE)
SIDE TILT	15 - 15 DEG. LEFT/RIGHT
KELLY BAR	6 ELEMENTS ZIP LOCK / 5 ELEMENTS ZIP LOCK W/EXT
ATTACHMENT WEIGHT	APPROX. 15,320 lbs [6,950 Kg] / 15,760 lbs [7,150 Kg] W/EXT
KELLY BAR WEIGHT	APPROX. 4,410 lbs [2,000kg] / APPROX. 5,900 lbs [2,700kg] W/EXT
TRANSPORT WEIGHT	APPROX. 72,000 lbs [32,660 Kg] / 74,000 lbs [33,570 Kg] W/EXT

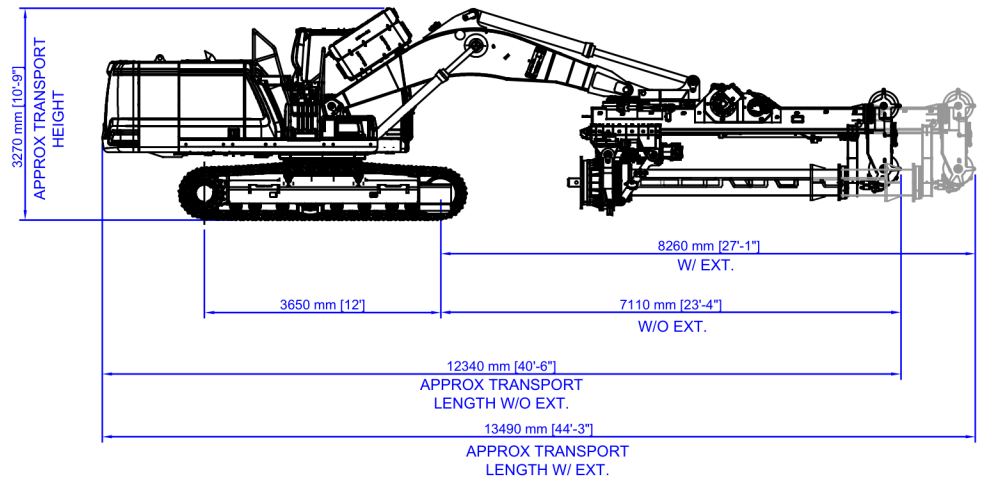
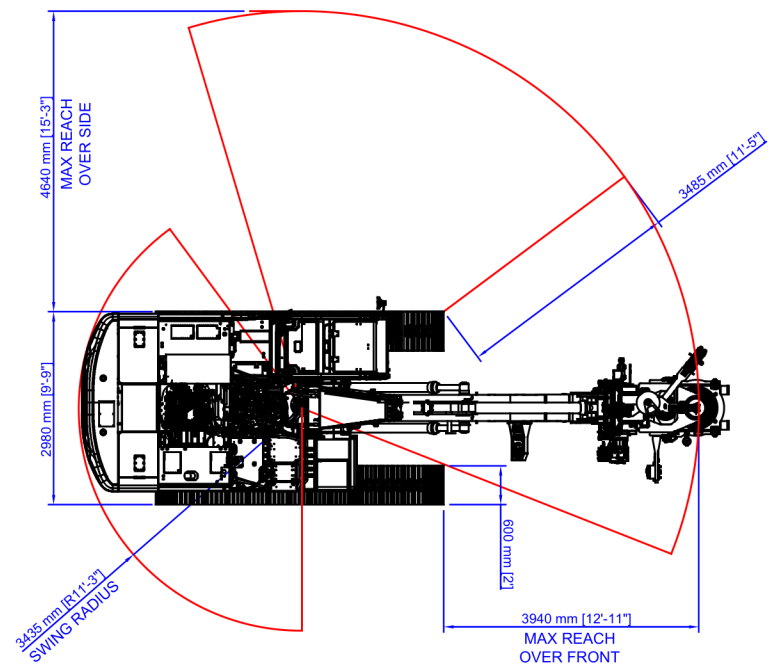
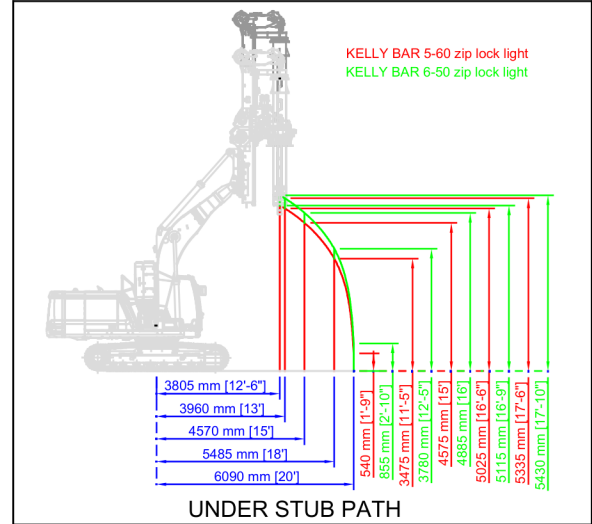

	REV	REVISION DESCRIPTION	REV#	APP#	DATE
	1	Initial			
	TITLE: LR50 CAT323 DRAWN: [Name] CHECKED: [Name] APPROVED: [Name]	PROJECT: LR50 CAT323 NG			
PROPRIETARY AND CONFIDENTIAL. THE INFORMATION CONTAINED IN THIS DRAWING IS THE SOLE PROPERTY OF CMI FOUNDATION. EQUIPMENT AND DIMENSIONS IN THIS DRAWING ARE SUBJECT TO CHANGE WITHOUT NOTICE. NO PART OF THIS DRAWING IS TO BE REPRODUCED OR TRANSMITTED IN ANY FORM OR BY ANY MEANS, WITHOUT THE WRITTEN PERMISSION OF CMI FOUNDATION. EQUIPMENT IS PROTECTED.	A1	10710.0050.000	0		