

Hydraulic Microdrilling Rig

# SM-4

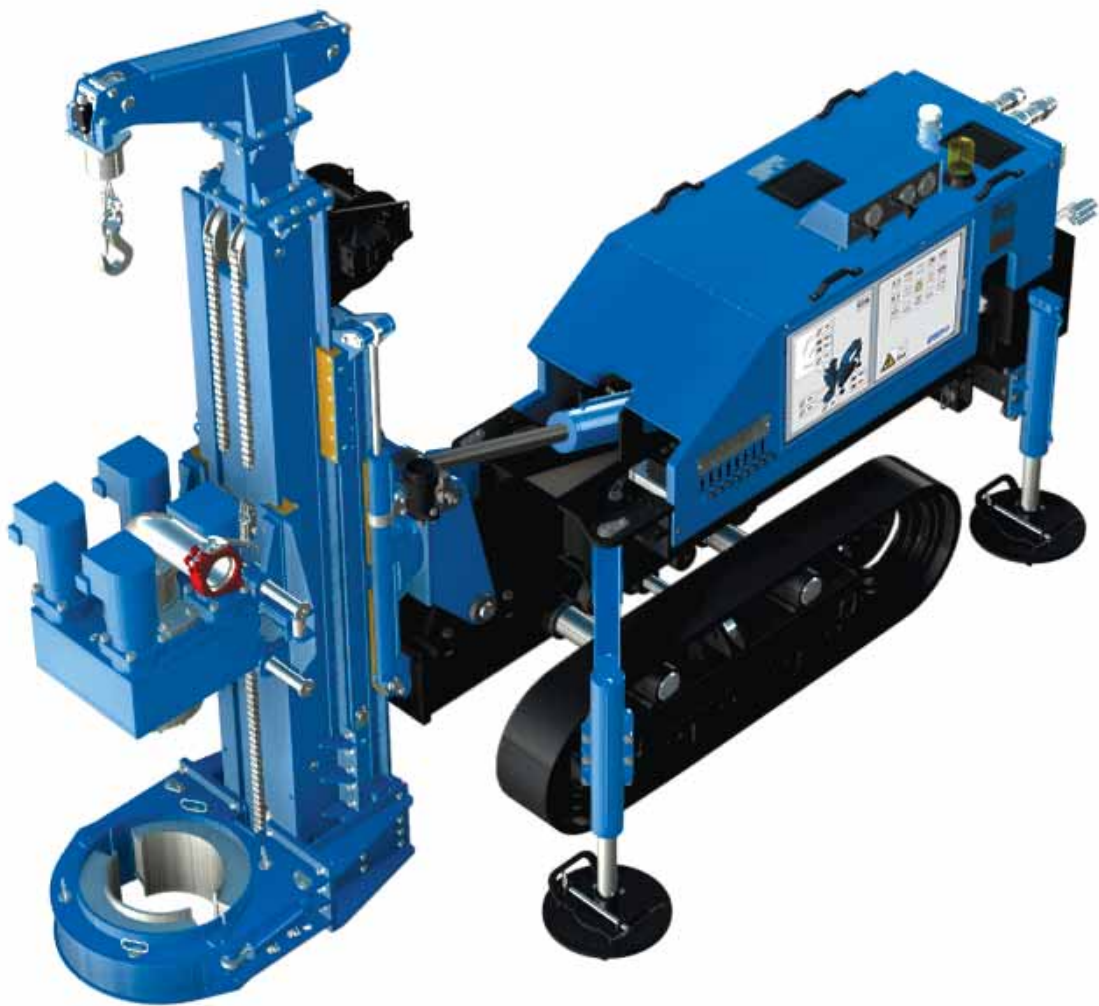

# SM-4 Hydraulic Microdrilling Rig

## APPLICATIONS

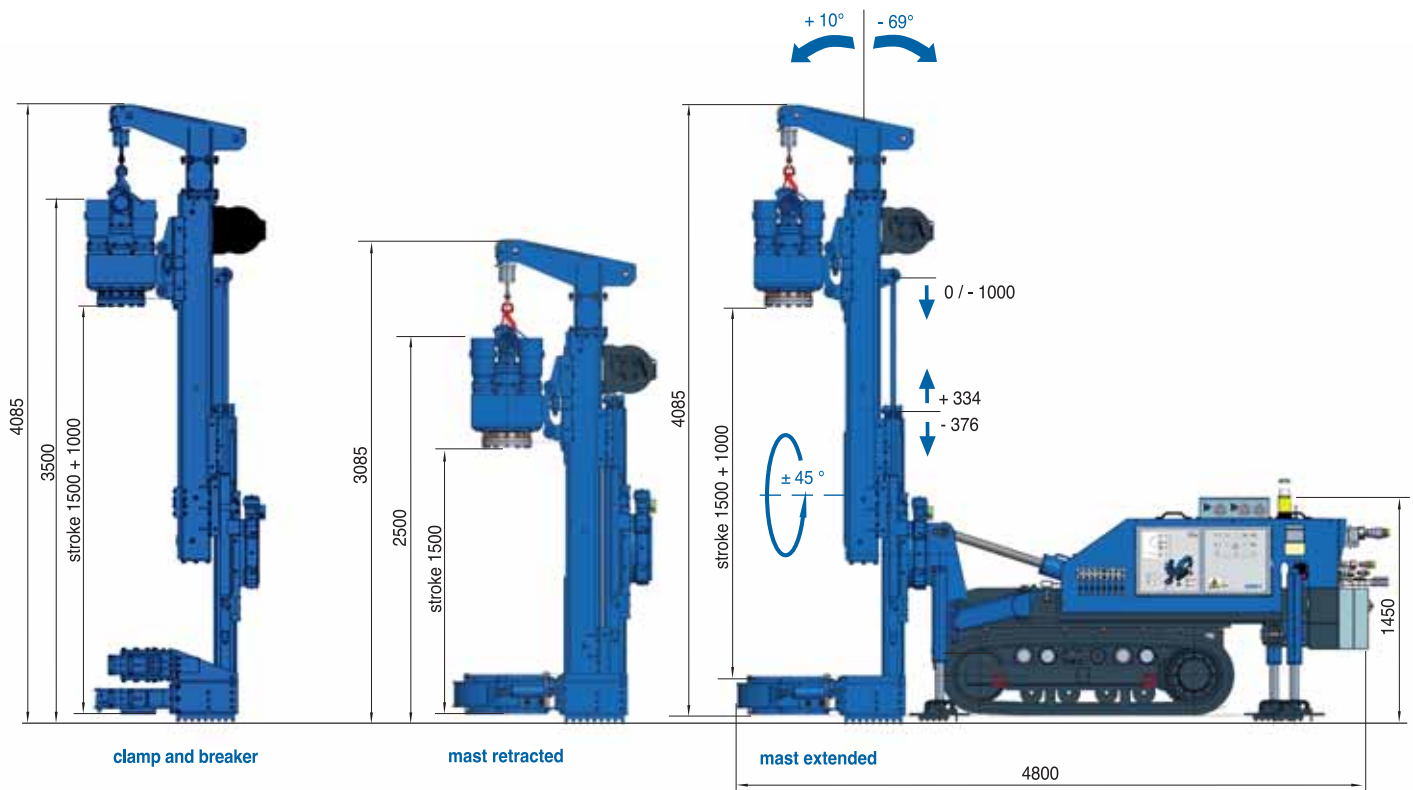

Hoist & Feed system		
Feed type	Cylinder	Cylinder
Feed stroke	1500 + 1000 mm	59.1 + 39.4 in
Maximum hoist pull/feed force	70 / 46 kN	15736 / 10341 lbf
Maximum speed (fast/low operation)	21 / 7 m/min	69 / 23 ft/min
Rotary head		
	HT3400V	HT3400V
Gear box type	3 ratios	3 ratios
Maximum torque	3350 daNm	24708 lbf*ft
Maximum drilling speed	58 rpm	58 rpm
Inner passage	134 mm	5.3 in

# SM-4 Hydraulic Microdrilling Rig

## TECHNICAL DATA SHEET

<b>Operating weight separated power pack (approx.)</b>	<b>3700 kg</b>	<b>8158.5 lb</b>
<b>Undercarriage</b>	<b>Fixed gauge</b>	<b>Fixed gauge</b>
- Track shoe width	250 mm	9.8 in
- Overall length	1971 mm	77.6 in
- Overall width	1180 mm	46.5 in
<b>Diesel Engine (optional)</b>		
- Make and model	DEUTZ - TCD 4.1 L04 4V Tier 4i	DEUTZ - TCD 4.1 L04 4V Tier 4i
- Power rating	115 kW @ 2000 rpm	154 HP @ 2000 rpm
- Sound power level and sound pressure level	LwA 115 - LpA 74 dB(A)	LwA 115 - LpA 74 dB(A)

<b>Operating weight base machine (approx.)</b>	<b>6400 kg</b>	<b>14112 lb</b>
<b>Undercarriage</b>	<b>Variable gauge</b>	<b>Variable gauge</b>
- Track shoe width	220 mm	8.7 in
- Overall length	1952 mm	76.9 in
- Overall width (ext/retr)	1200 / 740 mm	47.2 / 29.1 in
- Travelling speed	3,33 km/h	2.07 mph
- Ground stabilizers	n° 2 rotatable on front + n° 2 extendable on rear	n° 2 rotatable on front + n° 2 extendable on rear
<b>Hydraulic system</b>		
- Main pumps: variable axial pumps	200 l/min	53 US gal/min
- Set pressure main pumps	30 MPa	4351 psi
- Auxiliary pumps: gear pumps	86 + 32 l/min	22.7 + 8.5 US gal/min
- Hydraulic oil tank capacity	403 l	106 US gal
<b>Auger</b>		
- Nominal size	300 - 450 mm*	11.8 - 17.7 in*
<b>Casing</b>		
- Nominal size	340 - 510 mm	13.4 - 20 in
<b>Service winch</b>		
- 1st layer line pull (nominal/effective)	20 kN	4496 lbf
- 1st layer nominal rope speed	43 m/min	141 ft/min
- Rope diameter	8 mm	0.31 in

\* up to 5800 mm w/o casing

## STANDARD EQUIPMENT

- Extendable undercarriage with rubber crawler
- Telescopic drill mast
- Clamp and breaker 50-320 mm
- Prearrangement for mud pump
- Pneumatic inline DTH lubricator
- Cable remote for tramming
- Load Sensing hydraulic system
- Radio remote control for drilling operation
- Hydraulic control for kinematism

## OPTIONAL EQUIPMENT

- Separated Electric power pack (110 kW)
- Wide range of feed stroke
- Wide range of rotary heads
- Power pack on crawler track or on skid
- Triplex pump for Foam
- CFA kit
- Top hammer kit
- Jet grouting kit
- Integrated foam pump

# SM-4 Hydraulic Microdrilling Rig

## TRANSPORT, DIMENSIONS AND WEIGHTS

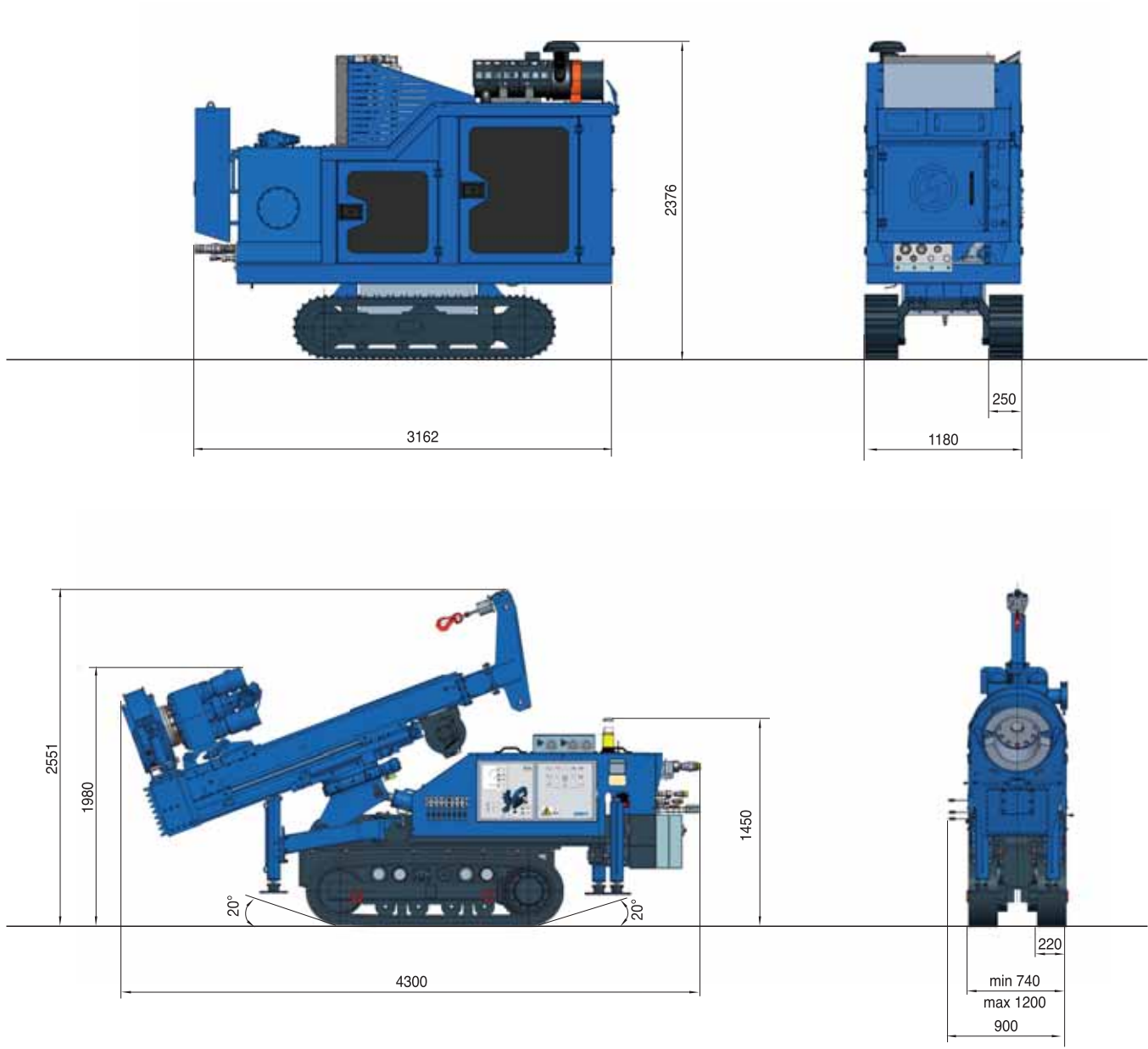

All technical data are purely indicative and subject to change without notice

Technical data sheet SM4-003 09/2014

Transport configuration		
<b>Length</b>	<b>4300 mm</b>	<b>169.3 in</b>
<b>Width</b>	<b>760 mm</b>	<b>29.9 in</b>
<b>Height</b>	<b>2000 mm</b>	<b>78.7 in</b>
<b>Weight</b>	<b>5800 kg</b>	<b>12787 lb</b>

This brochure has been edited and distributed by SOILMEC Spa. The present document cancels and override any previous ones. This brochure shall not be distributed, reproduced or exhibited without SOILMEC Spa. authorization in accordance with to SOILMEC web site disclaimer condition.

SOILMEC Spa distributes machinery and structures all over the world, supported by SOILMEC Spa subsidiary companies and dealers. The complete Soilmec network list is available on the web site [www.soilmec.it](http://www.soilmec.it)