

Pioneer Prime

PP1212S17L71



Typical Pump Configuration

Performance

Pioneer Prime series - vacuum assisted, end suction centrifugal pump

Bare shaft, frame mounted, fully automatic dry priming, vacuum assisted, run dry, heavy duty solids handling pump

Size	12" x 12" 300 x 300 mm
Flow, Max	9,000 USgpm 2070 m ³ /h 570 l/s
Head, Max	300 feet 90 meters
Flow at BEP	7,100 USgpm 1630 m ³ /h 450 l/s
Efficiency at BEP	72%
Solids Handling, Max	3.75" 95 mm
Operating Speed, Max	1800 rpm
Suction Connection	12" (300 mm) 150 ANSI Flanges
Delivery Connection	12" (300 mm) 150 ANSI Flanges
Bearing Lubrication	Oil STD Grease optional
Fasteners	Imperial

Applications

Dirty water	Raw water pumps
Sewage bypass	Flood pumps
Silt returns	Mine dewatering
Cooling pumps	

High pressure, high flow, heavy duty solids handling pump

Designed to run over a broad range of performance while delivering outstanding suction lift, the PP1212S17 is the solid choice. The rugged construction and modular design provide proven reliability and flexibility in the most demanding applications.

UltraPrime™ Priming System

Priming System	Mechanically Driven Diaphragm Style Vacuum Pump
Air Removal Capability	50 CFM
Priming Chamber	Single chamber with positive sealing air separation PosiValve™ with stainless steel float ball & linkage.
Discharge Check Valve	Swing Style - ductile iron with Buna-n Disc

Other Specifications

Mechanical Seal	Single seal w/ tungsten carbide vs. silicon carbide seal faces, Viton® elastomers, 300 series stainless steel hardware and spring, designed for indefinite dry running
Pump End Bearing	Roller Bearing
Drive End Bearing	Double Row Angular Contact
Shaft	17-4 PH Stainless Steel

Construction Materials

	Standard Construction	CD4MCu Stainless Steel
Impeller	CA6NM SS	CD4MCu
Volute	Ductile Iron ASTM A536 65-45-12	CD4MCu
Wear Ring	ASTM A48 Class 40 Gray Iron	316 SS
Suction Cover	Ductile Iron ASTM A536 65-45-12	CD4MCu
Bracket	Ductile Iron ASTM A536 65-45-12	CD4MCu
Backplate	Ductile Iron ASTM A536 65-45-12	CD4MCu

Mechanical Dimensions



PP1212S17

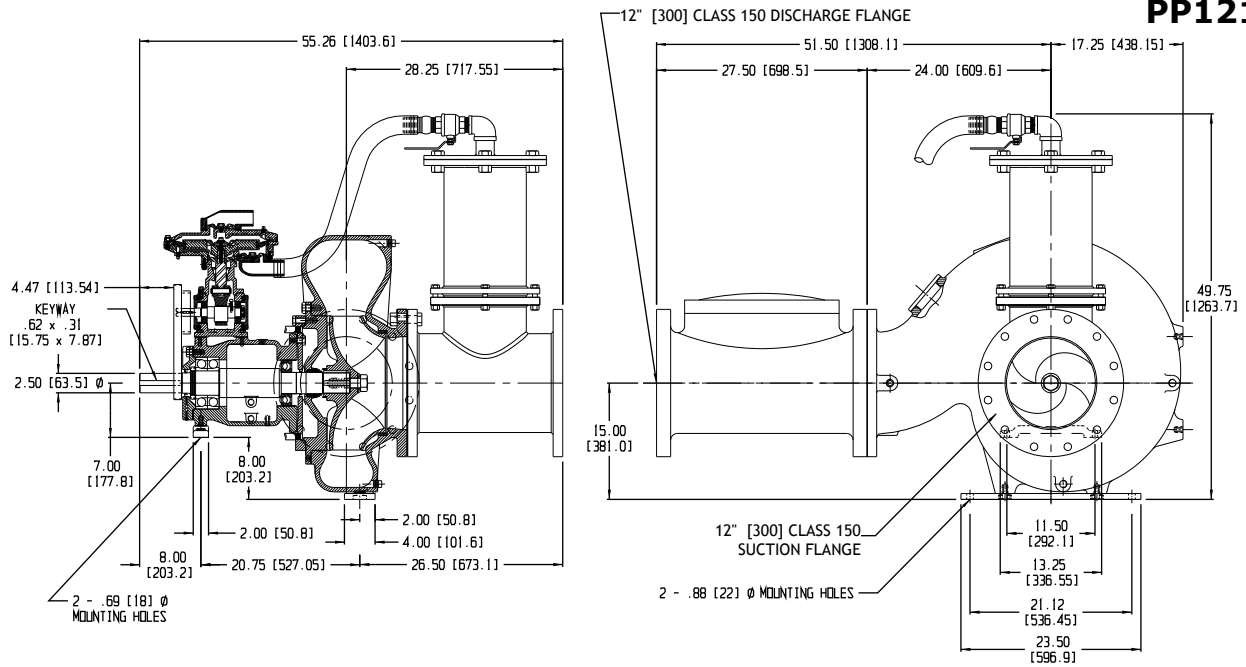

Performance Curve

Model: PP1212S17	Impeller Dia: 17.25"	Speed: Variable	Solids Size: 3.75"	Curve #07815HQ
------------------	----------------------	-----------------	--------------------	----------------

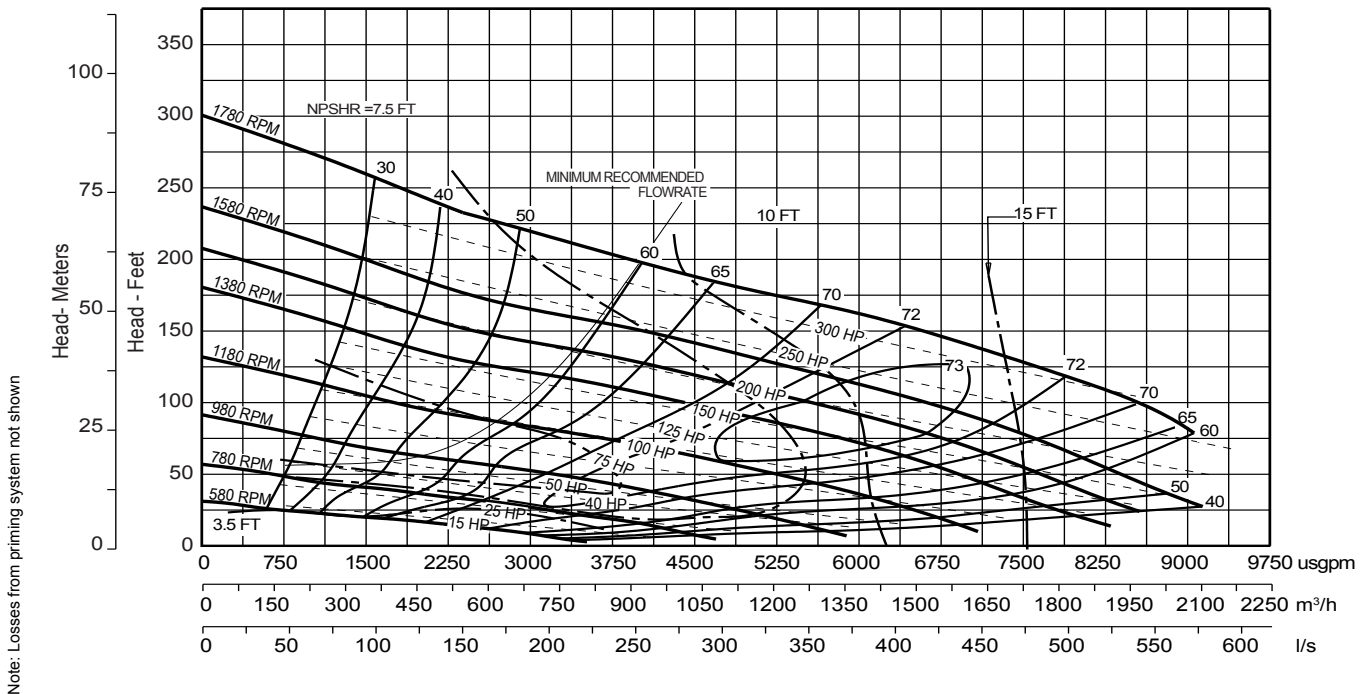

Corporate +1 (503) 266-4115 ■ EMEA +44 (0)1449 736777 ■ South Africa +27 (0) 118240085 ■ Australia +61 3 9988 1650

www.pioneerpump.com