



BIBO BS-2102.041

Small Portable Dewatering Pump

Capacity up to 41 l/sec. (650 GPM), heads up to 47 m. (155 ft.)



Applications:

The BS 2102 is ideal for fast dewatering of construction sites, mines, trenches, marine salvage, public works, deep excavations, etc.

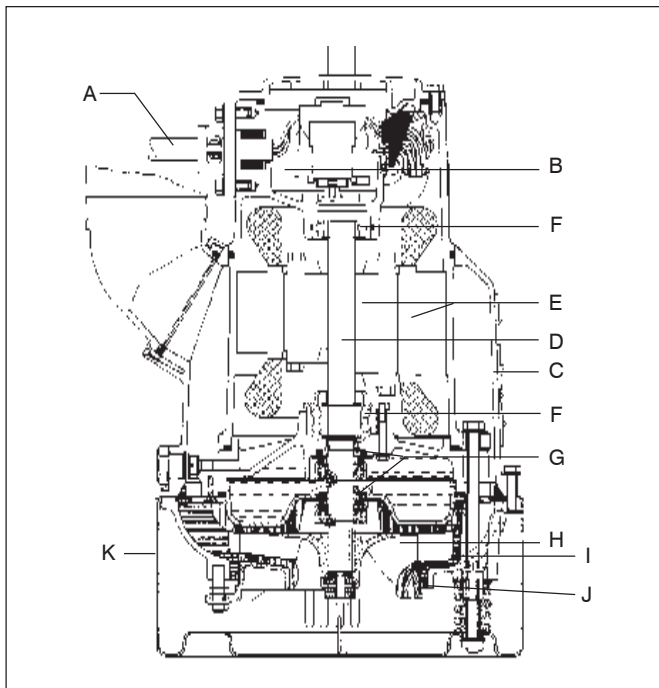

Specifications

- A **Cable.** Standard 16 m (50 ft.) of AWG 10/4 or 14/4 Subcab cable. Other lengths available.
 - B **Junction Chamber.** Cable entry incorporates a strain relief and grommet controlled compression sealing. Between the junction box and stator housing a rubber gland provides additional seal protection of the motor.
 - C **Pump Housing.** High strength, light weight aluminum alloy. Static seals are leakproof Nitrile rubber O rings in precision machined grooves, with controlled compression.
 - D **Shaft.** Stainless steel AISI 431
 - E **Motor.** Air filled, NEMA design B with class H (180°C) insulation. 2 pole, 3450 rpm, Shrink fit to the motor housing. Allows at least 10 starts per hour. Built in thermal sensors for additional motor overload protection.
 - F **Bearings.** Upper: single row ball bearing. Lower: double-row angular contact ball bearing.
 - G **Shaft Seals.** Independent double face seals running in an environmentally friendly, FDA approved (Standard #172.878) lubricant. Upper Seal: tungsten carbide/carbon. Lower seal: tungsten carbide/tungsten carbide. Oil quantity: 1.5 liters.
 - H **Impeller.** Multivane, open type. Material: alloyed white cast iron ASTM 532.80 Alloy 111A, hardened for high wear resistance to 60Rc hardness.
 - I **Diffuser.** Protected by polyurethane (Polylife) or Nitrile rubber liner. Adjustable to maintain pump's hydraulic performance.
 - J **Wear Plate.** Protected by polyurethane (Polylife) or Nitrile rubber liner.
 - K **Strainer.** Hot dip galvanized steel. 160 holes 1/4" x 1-1/2". Spring loaded to absorb heavy impact.
- Fasteners.** Stainless steel AISI 304.

Options:

Stainless steel impellers,
Warm Liquid versions

Approvals:

CSA approved to UL Standard #778 and CSA C22.2 #108.



Controls:(not shown)

Manual controls, magnetic starter type, providing short circuit and overload protection, housed in EEMAC3 enclosure. Other enclosure types (EEMAC4, EEMAC12) are optional.

Accessories:

Low suction collar, allowing pumping down to floor level; Tandem connection; Zinc anodes.

BIBO BS-2102.041

Performance Data

Power Input kW

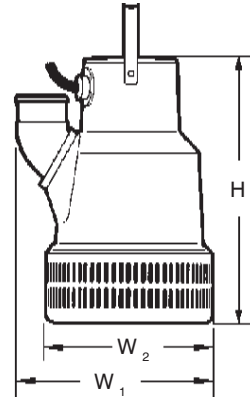
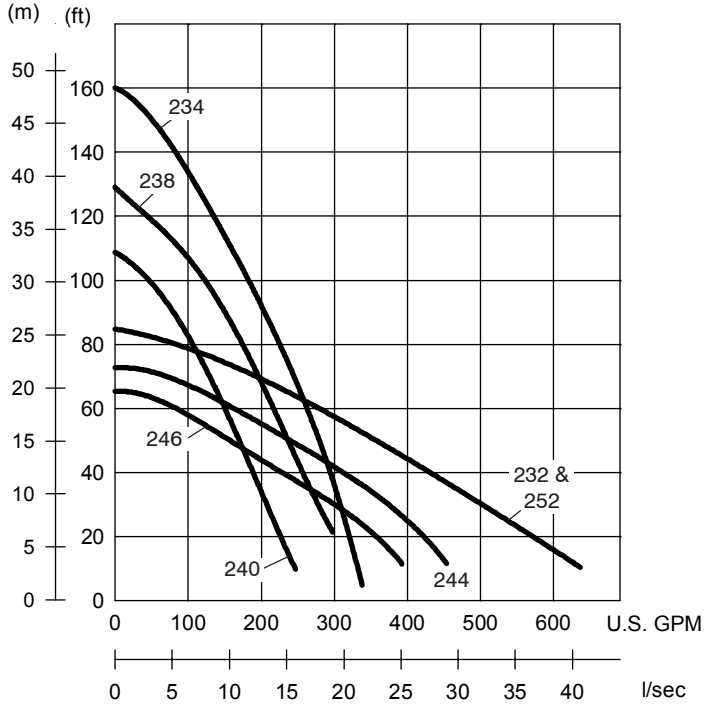
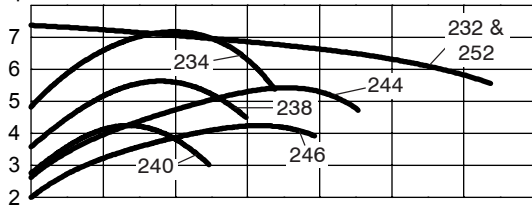

Dimensions

Discharge conn.	W ₁ inches	W ₁ mm	W ₂ inches	W ₂ mm	H inches	H mm	Weight lbs.	Weight kg	Tandem Conn.*
3" High Head									
3" - 8 NPSM (Male)	15 ^{3/8}	390	13 ^{3/16}	335	21	531	106	48	3" Hose Conn.
3" - 8 NPSM (Male) *	13 ^{1/4}	335	13 ^{3/16}	335	21	531	106	48	3" Hose Conn.
(Confined spaces) **	17 ^{1/4} max.								
3" Hose Conn. *	14 ^{3/4}	375	13 ^{3/16}	335	21	531	106	48	3" Hose Conn.
4" Standard									
4" - 8 NPSM (Male)	17	430	13 ^{3/16}	335	21	531	106	48	4" Hose Conn.
4" Hose Conn. *	18 ^{3/8} max.								
4" Hose Conn. *	15 ^{3/8}	390	13 ^{3/16}	335	21	531	106	48	4" Hose Conn.

* Optional

** Narrower to fit into confined spaces.

VERSION	IMP. CODE	HP	PHASE	VOLTS	FLA	STARTING CURRENT	CABLE SIZE AWG			
High Head HT 3"	240	4.5	1	230	21	45	10/4			
			3	230	25	109	10/4			
		5.8	3	230	15	114	14/4			
			3	460	7.3	50	14/4			
			3	600	5.7	37	14/4			
	234	8	3	230	21	139	10/4			
			3	460	10	82	14/4			
		3	3	600	7.9	62	14/4			
			Standard MT 4" 4"	246	4.5	1	230	21	45	10/4
						1	230	25	109	10/4
5.8	3	230			15	114	14/4			
	3	3		460	7.3	50	14/4			
		3		600	5.7	37	14/4			
232 252*	8	3	230	21	139	10/4				
		3	460	10	82	14/4				
		3	600	7.9	62	14/4				

* Stainless Steel impeller AISI 329

SALES • SERVICE • RENTALS

Coquitlam, BC, Tel.: (604) 941-6664, Fax: (604) 941-3659 • Calgary, AB, Tel.: (403) 279-8371, Fax: (403) 279-0948 • Edmonton, AB, Tel.: (780) 489-1961, Fax: (780) 486-5530
 Saskatoon, SK, Tel.: (306) 933-4849, Fax: (306) 931-0051 • Winnipeg, MB, Tel.: (204) 235-0050, Fax: (204) 235-0066 • Concord, ON, Tel.: (905) 760-7530, Fax: (905) 760-7527
 Ottawa, ON, Tel.: (613) 225-9600, Fax: (613) 225-5496 • Sudbury, ON, Tel.: (705) 560-2141, Fax: (705) 560-8260 • Thunder Bay, ON, Tel.: (807) 625-9960, Fax: (807) 625-9970
 Pointe-Claire, QC, Tel.: (514) 695-0133, Fax: (514) 695-7990 • Beauport, QC, Tel.: (418) 667-1694, Fax: (418) 666-9593 • Val d'Or, QC, Tel.: (819) 825-0792, Fax: (819) 825-5677
 Moncton, NB, Tel.: (506) 857-2244, Fax: (506) 859-8612 • Halifax, NS, Tel.: (902) 450-1177, Fax: (902) 450-1170 • St. John's, NL, Tel.: (709) 722-6717, Fax: (709) 722-9832

Flygt



ITT Industries