



BIBO BS-2071.010

Small Portable Dewatering Pump (Slim line)

7 1/4" O.D.; Capacity up to 320 GPM, Heads up to 175 ft.



Specifications

- A **Cable.** Standard 16 m (50 ft.) of SubCab cable. Other lengths available upon request.
 - B **Junction Chamber.** Cable entry incorporates a strain relief and grommet controlled compression sealing. Between the junction box and stator housing a rubber gland provides additional seal protection of the motor.
 - C **Pump Housing.** High strength, lightweight aluminum alloy. Static seals are leakproof Nitrile rubber O rings in precision machined grooves, with controlled compression.
 - D **Shaft.** Stainless steel - ANSI 329.
 - E **Motor.** Air filled, NEMA design B with class H (180°C) insulation; 2 pole, 3425 rpm. Shrink-fit to the motor housing. Allows at least 10 starts per hour. Built-in thermal sensors for additional motor overload protection.
 - F **Bearings.** Upper: single row ball bearing. Lower: double row angular contact ball bearing.
 - G **Shaft Seals.** Independent double face seals running in environmentally friendly, FDA approved (Standard #172.878) lubricant. Upper seal: tungsten carbide/carbon. Lower seal: tungsten carbide/tungsten carbide. Oil specs: 1.2 pints (0.6 l).
 - H **Impeller.** Multivane, open type. Material: alloyed white cast iron ASTM 532.80 Alloy IIIA, hardened for high wear resistance to 60 Rc hardness. Standard version has two stage impeller.
 - I **Diffuser.** Protected by polyurethane (Polylife) or Nitrile Rubber liner. Adjustable to maintain pump's hydraulic performance.
 - J **Wear Plate.** Protected by polyurethane (Polylife) or Nitrile Rubber liner.
 - K **Strainer.** Hot dip galvanized steel. 40 holes 5/16" x 1-15/16".
- Fasteners.** Stainless steel ANSI 304.

Applications:

Bibo BS-2071 is especially suited to use where space is limited; fit easily in a 8" pipe; ideal for fast dewatering of manholes, casings, caissons, etc.

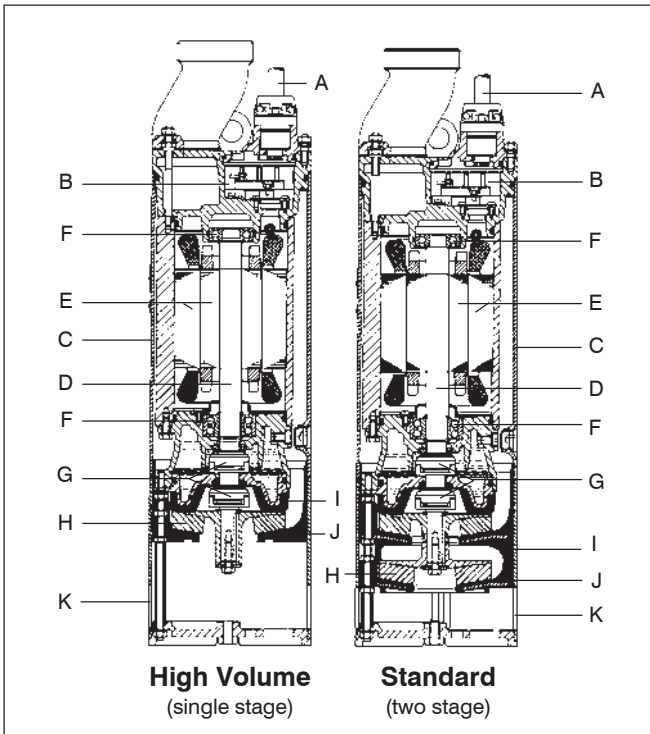

Options.

Stainless steel impellers; Warm liquid versions.

Approval:

CSA approved to UL Standard #778 and CSA C22.2 #108.



Controls (not shown).

Manual controls, magnetic starter type, providing thermal and overload protection, housed in EEMAC3 enclosure. Other enclosure types (EEMAC4, EEMAC12) are optional.

Accessories.

Tandem connection; Zinc anodes.

BIBO BS-2071.010

Performance Data

Power Input kW

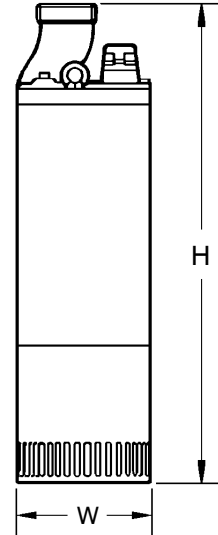
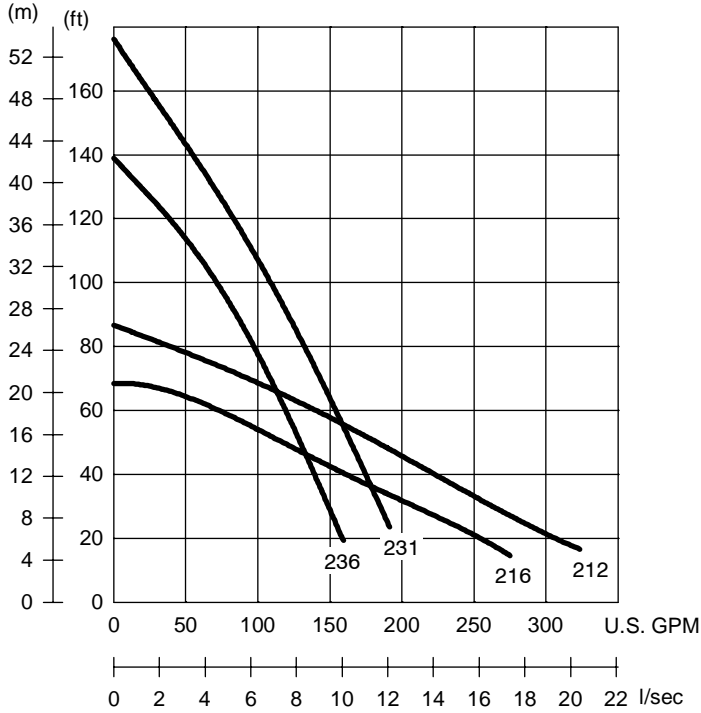
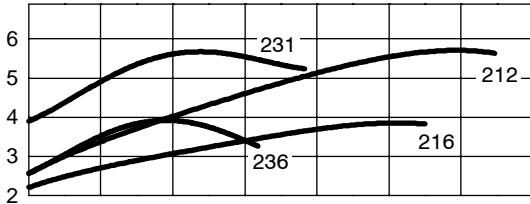

Dimensions

Discharge conn.	W inches	W mm	H inches	H mm	Weight lbs. kg	Tandem conn.*
2" Standard MT 2 Stages						
2" Hose*, NPSM 2-11½	7 1/4	185	27 3/4	705	68 31	2" Hose conn., NPSM 2-1½
3" High Volume LT						
3" Hose*, NPSM 3-8	7 1/4	185	27 3/4	705	68 31	3" Hose conn., NPSM 3-8

*Optional

VERSION	IMP. CODE	HP	PHASE	VOLTS	FLA	STARTING CURRENT	CABLE SIZE AWG
Standard MT 2"	236	4	1	230	18	68	12/7
	231	6	3	230	16	78	12/7
		6	3	460	8.1	43	14/7
		6	3	600	6.1	30	14/7
High Volume LT 3"	216	4	1	230	18	68	12/7
	212	6	3	230	16	78	12/7
		6	3	460	8.1	43	14/7
		6	3	600	6.1	30	14/7

SALES • SERVICE • RENTALS

Coquitlam, BC, Tel.: (604) 941-6664, Fax: (604) 941-3659 • Calgary, AB, Tel.: (403) 279-8371, Fax: (403) 279-0948 • Edmonton, AB, Tel.: (780) 489-1961, Fax: (780) 486-5530
 Saskatoon, SK, Tel.: (306) 933-4849, Fax: (306) 931-0051 • Winnipeg, MB, Tel.: (204) 235-0050, Fax: (204) 235-0066 • Concord, ON, Tel.: (905) 760-7530, Fax: (905) 760-7527
 Ottawa, ON, Tel.: (613) 225-9600, Fax: (613) 225-5496 • Sudbury, ON, Tel.: (705) 560-2141, Fax: (705) 560-8260 • Thunder Bay, ON, Tel.: (807) 625-9960, Fax: (807) 625-9970
 Pointe-Claire, QC, Tel.: (514) 695-0133, Fax: (514) 695-7990 • Beauport, QC, Tel.: (418) 667-1694, Fax: (418) 666-9593 • Val d'Or, QC, Tel.: (819) 825-0792, Fax: (819) 825-5677
 Moncton, NB, Tel.: (506) 857-2244, Fax: (506) 859-8612 • Halifax, NS, Tel.: (902) 450-1177, Fax: (902) 450-1170 • St. John's, NL, Tel.: (709) 722-6717, Fax: (709) 722-9832