



# American Pneumatic Tool

9949 Tabor Place, Santa Fe Springs, California, CA 90670, U.S.A.

## CHIPPING HAMMERS



For assistance in any sales, technical, maintenance or repair questions, please call APT @  
Phone: (800) 532-7402 or (562) 204-1555 • Fax: (800) 715-6502 or (562) 204-1773

Website: [www.apr-tools.com](http://www.apr-tools.com) • e-mail: [info@apr-tools.com](mailto:info@apr-tools.com)

TDS-1056 Rev A

© 2011 AMERICAN PNEUMATIC TOOLS, INC.



# American Pneumatic Tool

9949 Tabor Place, Santa Fe Springs, California, CA 90670, U.S.A.

## CHIPPING HAMMERS

### TOOL MAINTENANCE & REPAIR INFORMATION

#### FIELD OPERATION:

##### Before use:

1. On 650 Series tools, tighten the handle to 200 ft lbs. Check locking ring for correct fit.
2. On 260 Series tools, tighten nuts & bolts to 100 ft lbs.
3. Flush Air Tool Oil or 10W grade equivalent into the air inlet before connecting air hose. Install in-line oiler.
4. Check retainer and spring for wear or cracks, replace if necessary.
5. Clean any water and/or dirt from air hose before connecting it to the tool.

##### During use:

1. For your safety and that of others, keep tool against work at all times.
2. When moving from one work area to another, shut off air supply to tool.
3. Never run a tool when steel bit is not against the work.
4. Do not use tool as a wedge or prying instrument.
5. Always use tool with an in-line oiler.
6. On the 260 series tools, check all nuts to ensure they remain tight on the tool.
7. On the 650 series tools, check the handle is tight and the locking ring correctly engaged.

##### After use:

1. Flush tool with cleaning solvent, then refill with air tool oil or 10W equivalent.
2. Do not leave tool in water or dirt.
3. Check all nuts to ensure they are tight on the tool.
4. Store the tool well oiled.

#### TROUBLESHOOTING GUIDE:

##### If the tool runs erratically:

1. On the 260 series tools, check all nuts to ensure they remain tight on the tool.
2. On the 650 series tools, check the handle is tight and the locking ring is correctly fitted.
3. Flush cleaning solvent through the tool and then refill immediately with air tool oil or 10W equivalent.
4. If tool still runs erratically, disassemble and check the cleanliness of the valves, In addition, check for plugged cylinder ports.
5. Check for wear in the front bushing (round or hexagon), if worn, this will allow air to escape excessively from the tool.

##### If the tool is not hitting hard enough:

1. Check all the nuts, bolts and handles to ensure they are tight on the tool.
2. If all nuts, bolts and handles are tight, then check for wear on internal parts, if worn, the Parts should be replaced.
3. Check clearances between piston and cylinder bore carefully. Check front bushing for wear (round or hexagon).

##### If you cannot shut off the tool:

1. Immediately turn off the air source, and then disconnect the air supply.
2. Disassemble, and inspect the throttle valve and O rings for damage.

For assistance in any sales, technical, maintenance or repair questions, please call APT @

Phone: (800) 532-7402 or (562) 204-1555 • Fax: (800) 715-6502 or (562) 204-1773

Website: [www.apr-tools.com](http://www.apr-tools.com) • e-mail: [info@apr-tools.com](mailto:info@apr-tools.com)

TDS-1057 Rev A



# American Pneumatic Tool

9949 Tabor Place, Santa Fe Springs, California, CA 90670, U.S.A.

## MODEL 260 SERIES CHIPPING HAMMERS



The APT Chipping Hammers are used for work such as scaling, chiseling, removing concrete build-up from the inside of concrete mixers, light concrete demolition, cement finishing and form stripping.

### FEATURES

- New patented Ball Valve design (Pat. # 8,276,682 B2) - more forgiving of dirt and debris, easier to maintain, made from corrosion resistant material
- Ball-type throttle valve - less complicated, makes teasing the throttle easier
- Drop forged steel handle and collar
- Deep case hardened alloy steel cylinder
- Replaceable nose bushing
- 2 - bolt design for easier field maintenance
- Adjustable exhaust deflector
- Available in 3" and 4" strokes
- Tools come standard with:  
Standard oval collar retainer (Part # 7022)  
Locking Spring (Part # 1941)  
6 ft Whip hose assembly (Part # 9266)
- Optional quick change retainer systems available are:  
# 5550 Ball - type Retainer with Locking Spring  
# 18290 Ball - type, Bolt-on Retainer

### SPECIFICATIONS

Part #	18667	18670	18668	18671
Nose Bushing	.680 Round	.580 Hex	.680 Round	.580 Hex
Bore Diameter(inches)	1-1/8"		1-1/8"	
Stroke (inches)	3"		4"	
Blows per Minute	1650		1375	
CFM @ 90 psi	33 - 35		34 - 36	
Weight (lbs)	14		15	
Length (inches)	14-9/16"		15-9/16"	
Air Inlet Size	1/2" NPT FEMALE			

For assistance in any sales, technical, maintenance or repair questions, please call APT @  
Phone (800) 532-7402 or (562) 204-1555 • Fax (800) 715-6502 or (562) 204-1773

[www.apr-tools.com](http://www.apr-tools.com) • e-mail [info@apr-tools.com](mailto:info@apr-tools.com)

TDS-1058 Rev B

© 2011 AMERICAN PNEUMATIC TOOLS, INC.





# American Pneumatic Tool

9949 Tabor Place, Santa Fe Springs, California, CA 90670, U.S.A.

## MODEL 650 SERIES CHIPPING HAMMERS



The APT Chipping Hammers are used for work such as scaling, chiseling, removing concrete build-up from the inside of concrete mixers, light concrete demolition, cement finishing and form stripping.

### FEATURES

- Flapper valve design allows dirt to pass without stopping the tool
- Traditional pistol grip handle made from drop forged steel
- Deep case hardened alloy steel cylinder
- Replaceable nose bushing
- Adjustable exhaust deflector
- Available in 2", 3" and 4" strokes
- Tools come standard with:  
Standard oval collar retainer (Part # 7022)  
Locking Spring (Part # 1941)  
6 ft Whip hose assembly (Part # 9266)
- Optional quick change retainer systems available are:  
# 5550 Ball-type Retainer with lock spring  
# 18290 Bolt-on type

### SPECIFICATIONS

Part #	5298	5299	5300	5301	5302	5303
Nose Bushing	.680 Round	.580 Hex	.680 Round	.580 Hex	.680 Round	.580 Hex
Bore Diameter (inches)	1-1/8"		1-1/8"		1-1/8"	
Stroke (inches)	2"		3"		4"	
Blows per Minute	2100		1650		1375	
CFM @ 90 psi	32 - 34		33 - 35		34 - 36	
Weight (lbs)	12		14		16	
Length (inches)	13-1/4"		15-1/4"		16"	
Air Inlet Size	1/2" NPT FEMALE					

For assistance in any sales, technical, maintenance or repair questions, please call APT @  
Phone (800) 532-7402 or (562) 204-1555 • Fax (800) 715-6502 or (562) 204-1773

[www.apr-tools.com](http://www.apr-tools.com) • e-mail [info@apr-tools.com](mailto:info@apr-tools.com)

TDS-1060 Rev A

© 2011 AMERICAN PNEUMATIC TOOLS, INC.



# American Pneumatic Tool

9949 Tabor Place, Santa Fe Springs, California, CA 90670, U.S.A.

## APT MODEL 650 SERIES CHIPPING HAMMER

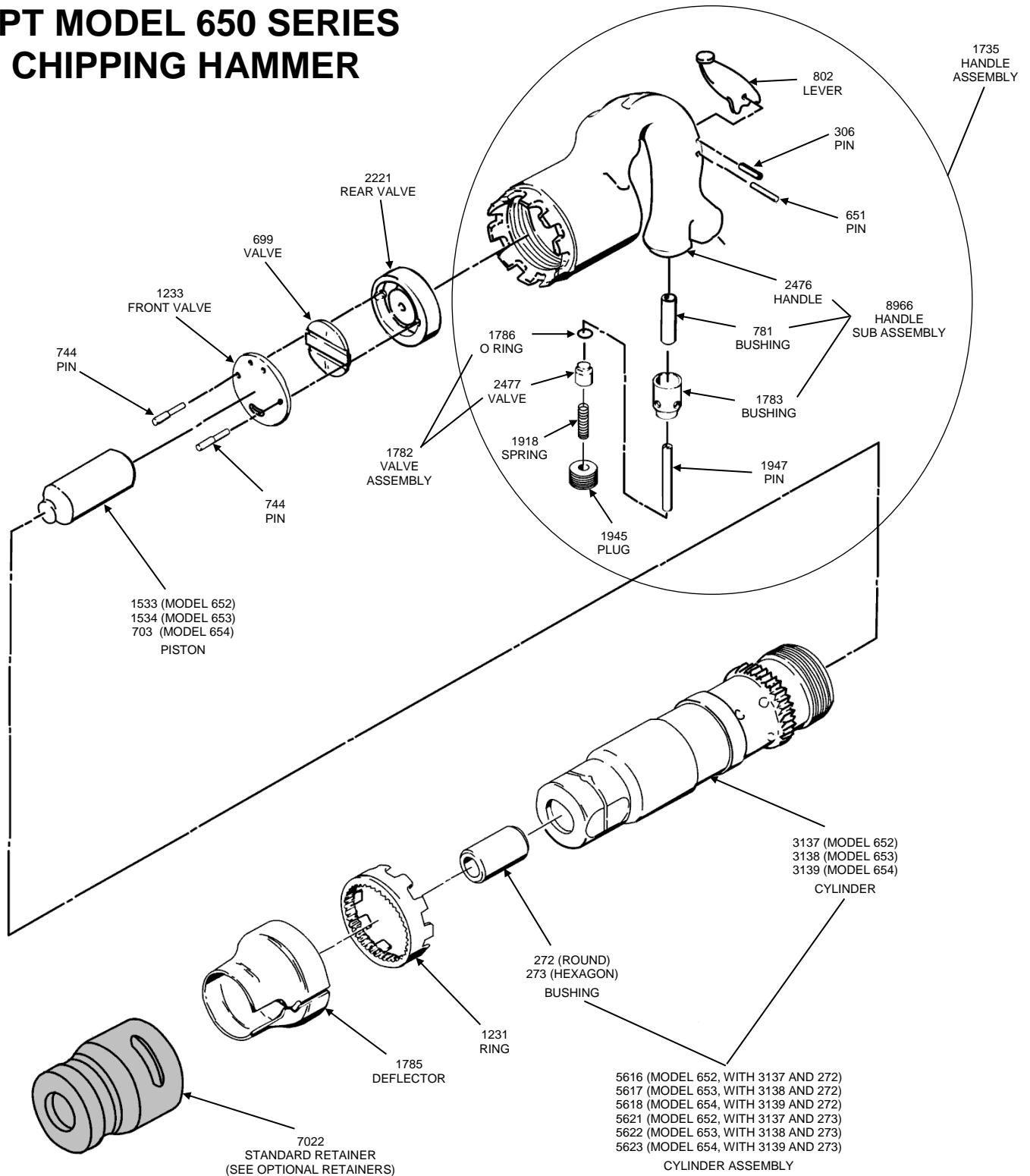

For assistance in any sales, technical, maintenance or repair questions, please call APT @  
Phone: (800) 532-7402 or (562) 204-1555 • Fax: (800) 715-6502 or (562) 204-1773

Website: [www.apr-tools.com](http://www.apr-tools.com) • e-mail: [info@apr-tools.com](mailto:info@apr-tools.com)

TDS-1061 Rev B

© 2011 AMERICAN PNEUMATIC TOOLS, INC.





# American Pneumatic Tool

9949 Tabor Place, Santa Fe Springs, California, CA 90670, U.S.A.

**BOLT-ON  
"QUICK CHANGE"**

**SAFETY  
RETAINER**

PART # 18290

- **LIGHTWEIGHT** Accessory tool changes are quick and easy-retainer stays mounted on the tool.
- **NO LOOSE PARTS** Locks firmly onto APT 260, 450 and 650 Series chippers without the need for typical retaining springs that are often lost or need to be replaced due to wear.
- **SECURE** Six points of contact (6 hardened steel balls) to retain all available round collar (hex or round shank) or oval collar steel types.
- **RENTAL FRIENDLY** No need to be concerned about different accessory steel; it accepts all types.
- **SAFE** Eliminates concern over retainer not being used when proper retaining spring is not available, or falling retainers and steel due to worn out springs.

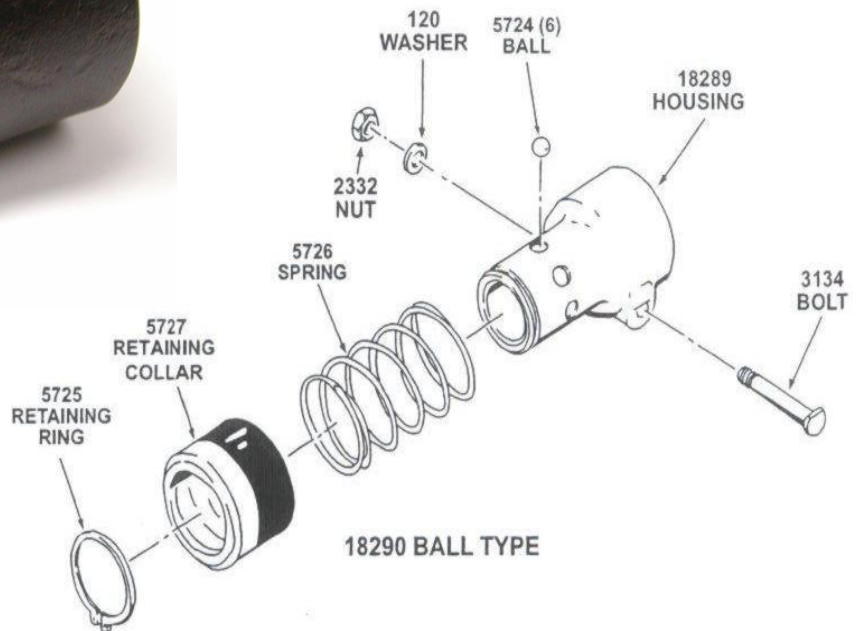

For assistance in any sales, technical, maintenance or repair questions, please call APT @  
Phone: (800) 532-7402 or (562) 204-1555 • Fax: (800) 715-6502 or (562) 204-1773

Website: [www.apr-tools.com](http://www.apr-tools.com) • e-mail: [info@apr-tools.com](mailto:info@apr-tools.com)

TDS-1063 Rev A

© 2011 AMERICAN PNEUMATIC TOOLS, INC



# American Pneumatic Tool

9949 Tabor Place, Santa Fe Springs, California, CA 90670, U.S.A.

## CHIPPING HAMMERS ACCESSORIES, SERVICE AND REPAIR KITS



### **M260**

- 16891 WHIP HOSE ASSEMBLY WITH OILER
- 9266 WHIP HOSE ASSEMBLY WITHOUT OILER
- 18786 O RING AND SEAL KIT
- 18795 BOLT REPLACEMENT KIT
- 3486 AIR INLET SWIVEL WITH 1/2" HOSE BARB
- 3389 AIR INLET SWIVEL WITH 3/8" MALE NPT

### **M650**

- 16891 WHIP HOSE ASSEMBLY WITH OILER
- 9266 WHIP HOSE ASSEMBLY WITHOUT OILER
- 18787 O RING AND SEAL KIT
- 3486 AIR INLET SWIVEL WITH 1/2" HOSE BARB
- 3389 AIR INLET SWIVEL WITH 3/8" MALE NPT

### **M450 (DISCONTINUED MODEL)**

- 9109 WHIP HOSE ASSEMBLY WITHOUT OILER
- 18787 O RING AND SEAL KIT
- 18649 BOLT REPLACEMENT KIT
- 3388 AIR INLET SWIVEL WITH 1/2" HOSE BARB
- 2698 AIR INLET SWIVEL WITH 3/8" MALE NPT

### **ALL MODELS**

- 1941 RETAINER SPRING
- 9431 STANDARD RETAINER + SPRING
- 5550 QUICK CHANGE RETAINER + SPRING
- 18290 QUICK CHANGE RETAINER – BOLT ON STYLE
- 18754 SAFETY CABLE, HOSE TO HOSE
- 18755 SAFETY CABLE, HOSE TO TOOL

For assistance in any sales, technical, maintenance or repair questions, please call APT @  
Phone: (800) 532-7402 or (562) 204-1555 • Fax: (800) 715-6502 or (562) 204-1773

Website: [www.apr-tools.com](http://www.apr-tools.com) • e-mail: [info@apr-tools.com](mailto:info@apr-tools.com)

TDS-1062 Rev A